

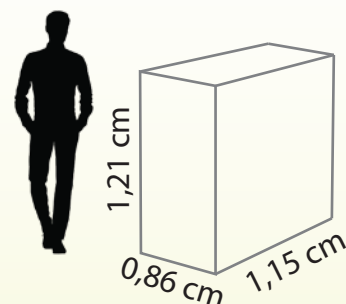



O2 sempre pelo melhor clima.

Climatizador o² clima 14

Parede



 Capacidade de
Climatização: **12.000m³**
vazão/hora

 Climatizador evaporativo de parede com
hélice única

 **Dimensões:**
Lado externo: (A X L X P) **1,21 X 1,15 X 0,86** mts.
Frontal/parede: (A X L) **0,89 X 0,89** mts.

Peso bruto (sem água): **68** kg

Consumo de energia: **1,16** kwh

Grelhas: **Plásticas Dupla Deflexão**

 Com
Controle
Remoto



BAIXO CONSUMO
DE ENERGIA



FABRICAÇÃO
NACIONAL COM
GARANTIA



MANUTENÇÃO,
ACESSÓRIOS E
PEÇAS

Climatizador o2clima 23

Parede

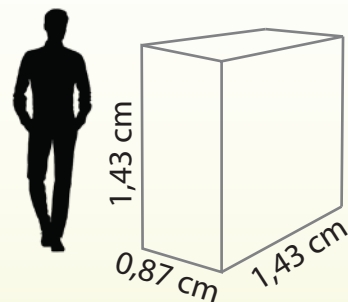

Capacidade de
Climatização: **23.000m³**
vazão/hora

Climatizador evaporativo de parede com
hélice única

Dimensões:
Lado externo: (A X L X P) **1,43 X 1,43 X 0,87** mts.
Frontal/parede: (A X L) **1,08 X 1,08** mts.

Peso bruto (sem água): **104,5** kg

Consumo de energia: **1,16** kwh

Grelhas: **Plásticas Dupla Deflexão**

Com
Controle
Remoto



BAIXO CONSUMO
DE ENERGIA



FABRICAÇÃO
NACIONAL COM
GARANTIA





MANUTENÇÃO,
ACESSÓRIOS E
PEÇAS

Climatizador o2clima 24

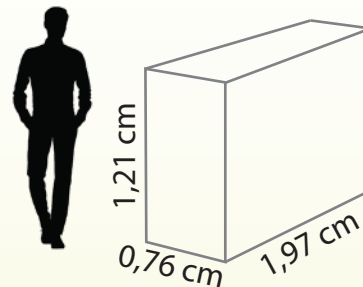
Parede



 Capacidade de
Climatização: **24.000m³**
vazão/hora

 Climatizador evaporativo de parede com
hélice dupla horizontal

 **Dimensões:**
Lado externo: (A X L X P) **1,21 X 1,97 X 0,76** mts.
Frontal/parede: (A X L) **0,90 X 1,72** mts.

Peso bruto (sem água): **114** kg

Consumo de energia: **1,57** kwh

Grelhas: **Plásticas Dupla Deflexão**

 Com
Controle
Remoto



BAIXO CONSUMO
DE ENERGIA



FABRICAÇÃO
NACIONAL COM
GARANTIA



MANUTENÇÃO,
ACESSÓRIOS E
PEÇAS

Climatizador o2clima 39

Parede

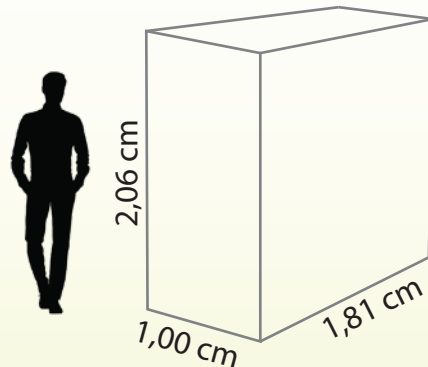

 Capacidade de
Climatização: **39.000m³**
vazão/hora

 Climatizador evaporativo de parede com
hélice única

 **Dimensões:**
Lado externo: (A X L X P) **2,06 X 1,81 X 1,00** mts.
Frontal/parede: (A X L) **1,40 X 1,40** mts.

Peso bruto (sem água): **161** kg

Consumo de energia: **1,63** kwh

Grelhas: **Plásticas Dupla Deflexão**



Com
Controle
Remoto



BAIXO CONSUMO
DE ENERGIA



FABRICAÇÃO
NACIONAL COM
GARANTIA



MANUTENÇÃO,
ACESSÓRIOS E
PEÇAS

Climatizador o² clima44

Parede

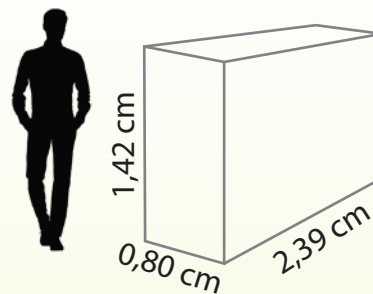

Capacidade de
Climatização: **44.000m³**
vazão/hora

Climatizador evaporativo de parede com
hélice dupla horizontal

Dimensões:
Lado externo: (A X L X P) **1,42 X 2,39 X 0,80** mts.
Frontal/parede: (A X L) **1,08 X 2,07** mts.

Peso bruto (sem água): **172** kg

Consumo de energia: **1,63** kwh

Grelhas: **Plásticas Dupla Deflexão**



BAIXO CONSUMO
DE ENERGIA



FABRICAÇÃO
NACIONAL COM
GARANTIA



MANUTENÇÃO,
ACESSÓRIOS E
PEÇAS

Climatizador o² clima44

Inox 304 Parede



**Aparelho
em Inox**

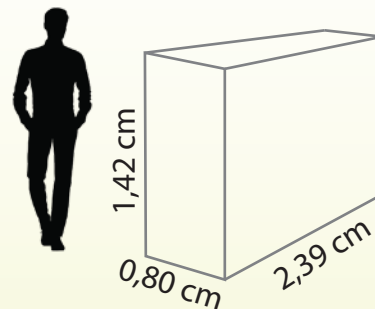

 Capacidade de
Climatização: **44.000m³**
vazão/hora

 Climatizador evaporativo de parede com
hélice dupla horizontal

 **Dimensões:**
Lado externo: (A X L X P) **1,42 X 2,39 X 0,80** mts.
Frontal/parede: (A X L) **1,08 X 2,07** mts.

Peso bruto (sem água): **122** kg

Consumo de energia: **1,63** kwh

Grelhas: **Plásticas Dupla Deflexão**

 Com
Controle
Remoto



BAIXO CONSUMO
DE ENERGIA



FABRICAÇÃO
NACIONAL COM
GARANTIA



MANUTENÇÃO,
ACESSÓRIOS E
PEÇAS

Climatizador o² clima 77

Parede

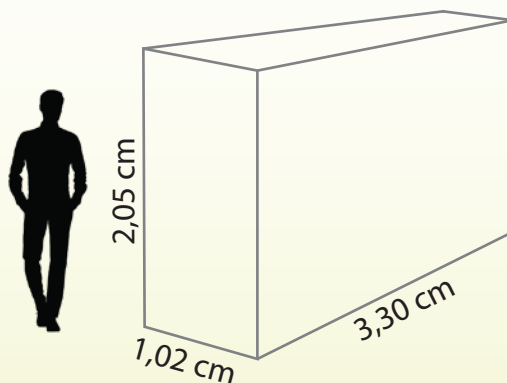

☹️ Capacidade de
Climatização: **77.000m³**
vazão/hora

✿✿ Climatizador evaporativo de parede com
hélice dupla horizontal



Dimensões:

Lado externo: (A X L X P) **2,05 X 3,30 X 1,02** mts.
Frontal/parede: (A X L) **1,43 X 2,82** mts.

Peso bruto (sem água): **243,5** kg

Consumo de energia: **2,75** kwh

Grelhas: **Plásticas Dupla Deflexão**



Com
Controle
Remoto



BAIXO CONSUMO
DE ENERGIA



FABRICAÇÃO
NACIONAL COM
GARANTIA



MANUTENÇÃO,
ACESSÓRIOS E
PEÇAS

Climatizador o² clima 28

Sky



Aparelho de teto

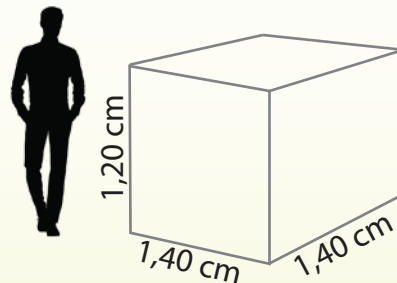

 Capacidade de
Climatização: **28.000m³**
vazão/hora

 Climatizador evaporativo de teto com
hélice única

 **Dimensões:**
Lado externo: (A X L X P) **1,20 X 1,40 X 1,40** mts.

Peso bruto (sem água): **102** kg

Consumo de energia: **1,22** kwh

Grelhas: **4 lados ou Pirâmide**

 Com
Controle
Remoto



BAIXO CONSUMO
DE ENERGIA



FABRICAÇÃO
NACIONAL COM
GARANTIA



MANUTENÇÃO,
ACESSÓRIOS E
PEÇAS

Climatizador o² clima42

Sky



**Aparelho
de teto**

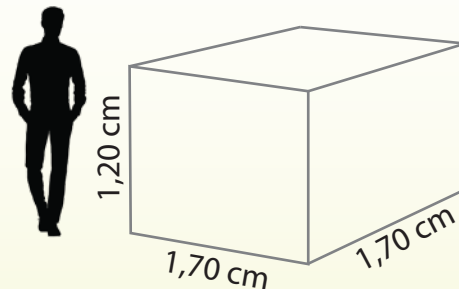

 Capacidade de
Climatização: **42.000m³**
vazão/hora

 Climatizador evaporativo de teto com
hélice única

 **Dimensões:**
Lado externo: (A X L X P) **1,20 X 1,70 X 1,70mts.**

Peso bruto (sem água): **160 kg**

Consumo de energia: **1,38 kwh**

Grelhas: **4 lados ou Pirâmide**

 Com
Controle
Remoto



BAIXO CONSUMO
DE ENERGIA



FABRICAÇÃO
NACIONAL COM
GARANTIA



MANUTENÇÃO,
ACESSÓRIOS E
PEÇAS

Climatizador o2clima07

Móvel



Aparelho móvel

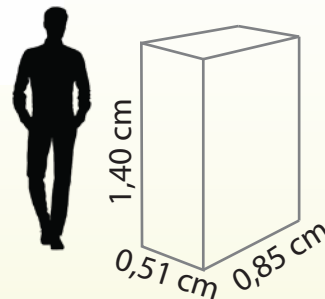

Capacidade de
Climatização: **7.000m³**
vazão/hora

Climatizador evaporativo móvel com
hélice única vertical

Dimensões:
Lado externo: (A X L X P) **1,40 X 0,85 X 0,51** mts.

Peso bruto (sem água): **36** kg

Consumo de energia: **0,20** kwh

Grelhas: **Plásticas Dupla Deflexão**

Obs.: Produto importado



BAIXO CONSUMO
DE ENERGIA



PRODUTO
IMPORTADO



MANUTENÇÃO,
ACESSÓRIOS E
PEÇAS

Climatizador o²clima 25

Móvel



Aparelho móvel

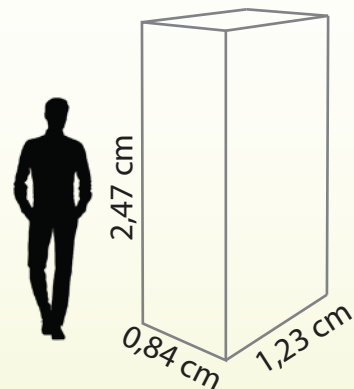

Capacidade de
Climatização: **25.000m³**
vazão/hora

Climatizador evaporativo móvel com
hélice dupla vertical

Dimensões:
Lado externo: (A X L X P) **2,47 X 1,23 X 0,84** mts.

Peso bruto (sem água): **117** kg

Consumo de energia: **1,57** kwh

Grelhas: **Plásticas Dupla Deflexão**

Obs.: Tela de proteção – NR12



Com
Controle
Remoto



BAIXO CONSUMO
DE ENERGIA



FABRICAÇÃO
NACIONAL COM
GARANTIA



MANUTENÇÃO,
ACESSÓRIOS E
PEÇAS

Climatizador o² clima45

Móvel



Aparelho móvel

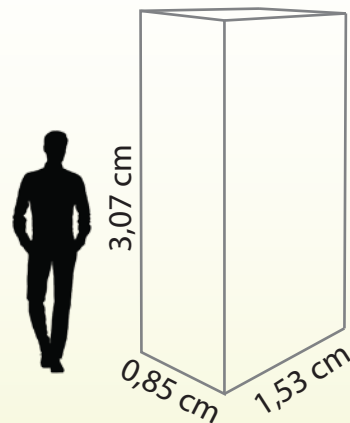

Capacidade de
Climatização: **45.000m³**
vazão/hora

Climatizador evaporativo móvel com
hélice dupla vertical

Dimensões:
Lado externo: (A X L X P) **3,07 X 1,53 X 0,85** mts.

Peso bruto (sem água): **217** kg

Consumo de energia: **1,63** kwh

Grelhas: **Plásticas Dupla Deflexão**

Obs.: Tela de proteção – NR12

Com
Controle
Remoto



BAIXO CONSUMO
DE ENERGIA



FABRICAÇÃO
NACIONAL COM
GARANTIA



MANUTENÇÃO,
ACESSÓRIOS E
PEÇAS

Exaustor o²clima 13

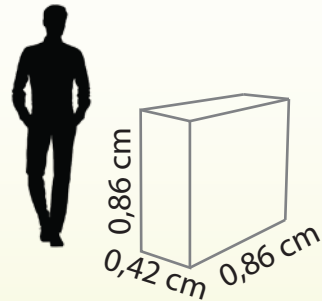

≡ Capacidade
de Exaustão: **13.000m³**
ar/hora

✿ Exaustor de ar com hélice única

⚙ **Dimensões:**
Lado externo: (A X L X P) **0,86 X 0,86 X 0,42** mts.

Peso bruto (sem água): **42,5** kg

Consumo de energia: **0,75** kwh

Grelhas: **Plásticas**



BAIXO CONSUMO
DE ENERGIA



FABRICAÇÃO
NACIONAL COM
GARANTIA



MANUTENÇÃO,
ACESSÓRIOS E
PEÇAS

Exaustor o² clima 26

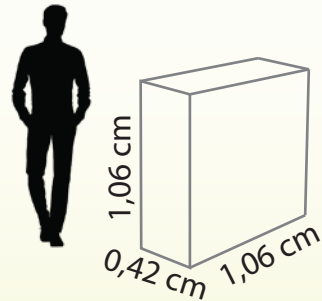

≡ Capacidade
de Exaustão: **26.000m³**
ar/hora

✿ Exaustor de ar com hélice única

⚙ **Dimensões:**
Lado externo: (A X L X P) **1,06 X 1,06 X 0,42** mts.

Peso bruto (sem água): **53,5** kg

Consumo de energia: **0,75** kwh

Grelhas: **Plásticas**



BAIXO CONSUMO
DE ENERGIA



FABRICAÇÃO
NACIONAL COM
GARANTIA



MANUTENÇÃO,
ACESSÓRIOS E
PEÇAS

Exaustor o² clima46

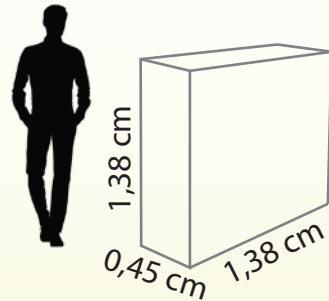

≡ Capacidade
de Exaustão: **46.000m³**
ar/hora

✿ Exaustor de ar com hélice única

⚙ **Dimensões:**
Lado externo: (A X L X P) **1,38X 1,38 X 0,45** mts.

Peso bruto (sem água): **80,5** kg

Consumo de energia: **1,10** kwh

Grelhas: **Plásticas**



BAIXO CONSUMO
DE ENERGIA



FABRICAÇÃO
NACIONAL COM
GARANTIA



MANUTENÇÃO,
ACESSÓRIOS E
PEÇAS

O² clima

Climatização e Refrigeração

Diferenciais:

- **Pintura eletrostática:** Pintura com tinta epóxi, tinta a pó aplicada eletrostaticamente
- **Motores de alta performance em alumínio:** Garantindo melhor economia de energia e desempenho
- **Controle Remoto:** Controle de temperatura inteligente
- **Hélice de inox:** Pás de inox com cubos de nylon garantindo a eliminação de ruídos
- **Controle IHM:** Interface homem/máquina

Vantagens:

- Alto desempenho
- Qualidade e durabilidade
- Fácil manutenção
- Baixo consumo
- Garantia e entrega em todo o Brasil
- Indústria brasileira



BAIXO CONSUMO
DE ENERGIA



FABRICAÇÃO
NACIONAL COM
GARANTIA



MANUTENÇÃO,
ACESSÓRIOS E
PEÇAS

LOCAÇÃO

Consulte também a disponibilidade de equipamentos para locação.

A O2 clima dispõe de peças e acessórios para manutenção

- Placas evaporativas
- Bomba submersa
- Hélices com cubo de nylon
- Motores
- Inversores
- Kits para limpeza

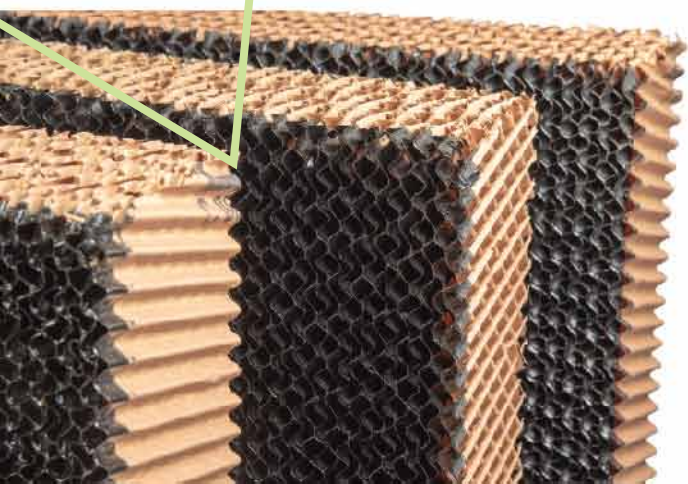
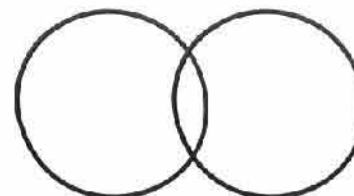





Acesse nosso site e saiba mais:

www.o2clima.com.br

Compre com o cartão BNDES em até 48X. *Sujeito a aplicação de juros, consulte. Aceitamos pagamentos pelos cartões CIELO, VISA E MASTERCARD, informe-se sobre a disponibilidade.

Envie seu email ou ligue: **(45) 3197-9179** 
comercial@o2clima.com.br **(45) 92000-0968** 

O2 Empresarial Indústria e Comércio de Máquinas Ltda. - CNPJ: 30.845.865/0001-10
Endereço: Rua Horácio Ribeiro dos Reis, 504 – Bairro Cataratas - Cascavel – PR | CEP 85.817-600

Revisado em 29/11/2019